

PART - A (PHYSICS)

1. A convex lens is put 10 cm from a light source and it makes a sharp image on a screen, kept 10 cm from the lens. Now a glass block (refractive index 1.5) of 1.5 cm thickness is placed in contact with the light source. To get the sharp image again, the screen is shifted by a distance d . Then d is:
- (A) 1.1 cm away from the lens (B) 0
(C) 0.55 cm towards the lens (D) 0.55 cm away from the lens

2. A resistance is shown in the figure. Its value and tolerance are given respectively by:
- (A) 270Ω , 10%
(B) $27 \text{ k}\Omega$, 10%
(C) $27 \text{ k}\Omega$, 20%
(D) 270Ω , 5%

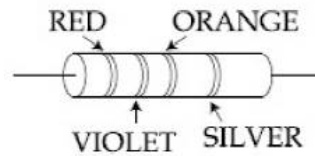

3. Drift speed of electrons, when 1.5 A of current flows in a copper wire of cross section 5 mm^2 , is v . If the electron density in copper is $9 \times 10^{28} / \text{m}^3$ the value of v in mm/s is close to (Take charge of electron to be $= 1.6 \times 10^{-19} \text{ C}$)
- (A) 0.02 (B) 3
(C) 2 (D) 0.2

4. An L-shaped object, made of thin rods of uniform mass density, is suspended with a string as shown in figure. If $AB = BC$, and the angle made by AB with downward vertical is θ , then:

- (A) $\tan \theta = \frac{1}{2\sqrt{3}}$ (B) $\tan \theta = \frac{1}{2}$
(C) $\tan \theta = \frac{2}{\sqrt{3}}$ (D) $\tan \theta = \frac{1}{3}$

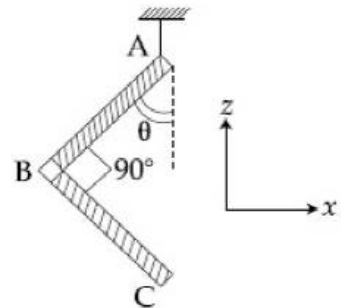

5. A particle is moving with a velocity $\vec{v} = K(y\hat{i} + x\hat{j})$, where K is a constant. The general equation for its path is:
- (A) $y = x^2 + \text{constant}$ (B) $y^2 = x + \text{constant}$
(C) $y^2 = x^2 + \text{constant}$ (D) $xy = \text{constant}$

6. A mixture of 2 moles of helium gas (atomic mass = 4 u), and 1 mole of argon gas (atomic mass = 40 u) is kept at 300 K in a container. The ratio of their rms speeds

$\left[\frac{V_{\text{rms}}(\text{helium})}{V_{\text{rms}}(\text{argon})} \right]$, is close to:

- (A) 3.16 (B) 0.32
(C) 0.45 (D) 2.24

7. A current loop, having two circular arcs joined by two radial lines is shown in the figure. It carries a current of 10 A. The magnetic field at point O will be close to:
 (A) 1.0×10^{-7} T
 (B) 1.5×10^{-7} T
 (C) 1.5×10^{-5} T
 (D) 1.0×10^{-5} T

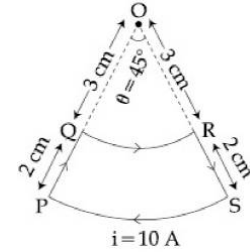

8. A block of mass m , lying on a smooth horizontal surface, is attached to a spring (of negligible mass) of spring constant k . The other end of the spring is fixed, as shown in the figure. The block is initially at rest in an equilibrium position. If now the block is pulled with a constant force F , the maximum speed of the block is

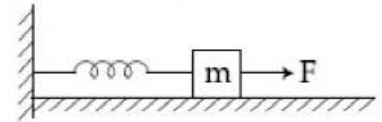

- (A) $\frac{2F}{\sqrt{mk}}$ (B) $\frac{F}{\pi\sqrt{mk}}$
 (C) $\frac{\pi F}{\sqrt{mk}}$ (D) $\frac{F}{\sqrt{mk}}$

9. For a uniformly charged ring of radius R , the electric field on its axis has the largest magnitude at a distance h from its centre. Then value of h is:

- (A) $\frac{R}{\sqrt{5}}$ (B) $\frac{R}{\sqrt{2}}$
 (C) R (D) $R\sqrt{2}$

10. Two coherent sources produce waves of different intensities which interfere. After interference, the ratio of the maximum intensity to the minimum intensity is 16. The intensity of the waves are in the ratio:

- (A) 16 : 9 (B) 25 : 9
 (C) 4 : 1 (D) 5 : 3

11. Surface of certain metal is first illuminated with light of wavelength $\lambda_1 = 350$ nm and then, the light of wavelength $\lambda_2 = 540$ nm. It is found that the maximum speed of the photo electrons in the two cases differ by a factor of 2. The work function of the metal (in eV) is

close to: (Energy of photon = $\frac{1240}{\lambda(\text{in nm})}$ eV)

- (A) 1.8 (B) 2.5
 (C) 5.6 (D) 1.4

12. Temperature difference of 120°C is maintained between two ends of a uniform rod AB of length $2L$. Another bent rod PQ, of same cross-section as AB and length $\frac{3L}{2}$, is connected across AB (See figure). In steady state, temperature difference between P and Q will be close to:

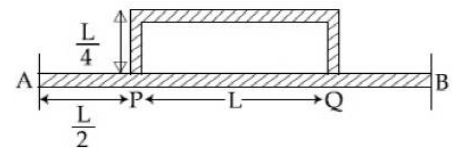

- (A) 45°C
 (B) 75°C
 (C) 60°C
 (D) 35°C

13. A gas can be taken from A to B via two different processes ACB and ADB. When path ACB is used 60 J of heat flows into the system and 30 J of work is done by the system. If path ADB is used work done by the system is 10 J. the heat flow into the system in path ADB is
 (A) 40 J (B) 80 J
 (C) 100 J (D) 20 J

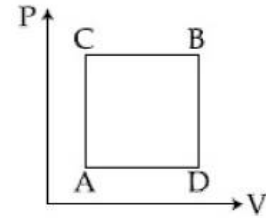

14. Consider a tank made of glass (refractive index 1.5) with a thick bottom. It is filled with a liquid of refractive index μ . A student finds that, irrespective of what the incident angle i (see figure) is for a beam of light entering the liquid, the light reflected from the liquid glass interface is never completely polarized. For this to happen, the minimum value of μ is

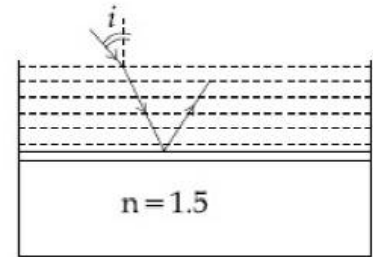

- (A) $\sqrt{\frac{5}{3}}$ (B) $\frac{3}{\sqrt{5}}$
 (C) $\frac{5}{\sqrt{3}}$ (D) $\frac{4}{3}$

15. Mobility of electron in a semiconductor is defined as the ratio of their drift velocity to the applied electric field. If, for an n-type semiconductor, the density of electrons is 10^{19} m^{-3} and their mobility is $1.6 \text{ m}^2/(\text{V}\cdot\text{s})$ then the resistivity of the semiconductor (since it is an n-type semiconductor contribution of holes is ignored) is close to:

- (A) $2 \Omega\text{m}$ (B) $4 \Omega\text{m}$
 (C) $0.4 \Omega\text{m}$ (D) $0.2 \Omega\text{m}$

16. A plane electromagnetic wave of frequency 50 MHz travels in free space along the positive x-direction. At a particular point in space and time, $\vec{E} = 6.3\hat{j} \text{ V/m}$. The corresponding magnetic field \vec{B} , at that point will be

- (A) $18.9 \times 10^{-8} \hat{k}\text{T}$ (B) $2.1 \times 10^{-8} \hat{k}\text{T}$
 (C) $6.3 \times 10^{-8} \hat{k}\text{T}$ (D) $18.9 \times 10^8 \hat{k}\text{T}$

17. Three charges $+Q$, q , $+Q$ are placed respectively, at distance, 0, $d/2$ and d from the origin, on the x-axis. If the net force experienced by $+Q$, placed at $x = 0$, is zero, then value of q is

- (A) $-Q/4$ (B) $+Q/2$
 (C) $+Q/4$ (D) $-Q/2$

18. A copper wire is stretched to make it 0.5% longer. The percentage change in its electric resistance if its volume remains unchanged is

- (A) 2.0% (B) 2.5%
 (C) 1.0% (D) 0.5%

19. A sample of radioactive material A, that has an activity of 10 mCi ($1 \text{ Ci} = 3.7 \times 10^{10}$ decays/s), has twice the number of nuclei as another sample of different radioactive material B which has an activity of 20 mCi. The correct choices for half-lives of A and B would then be respectively:

- (A) 5 days and 10 days (B) 10 days and 40 days
 (C) 20 days and 5 days (D) 20 days and 10 days

20. A heavy ball of mass M is suspended from the ceiling of car by a light string of mass m ($m \ll M$). When the car is at rest, the speed of transverse waves in the string is 60 ms^{-1} . When the car has acceleration a , the wave-speed increases to 60.5 ms^{-1} . The value of a , in terms of gravitational acceleration g is closest to:

- (A) $\frac{g}{30}$ (B) $\frac{g}{5}$
 (C) $\frac{g}{10}$ (D) $\frac{g}{20}$

21. A conducting circular loop made of a thin wire, has area $3.5 \times 10^{-3} \text{ m}^2$ and resistance 10Ω . It is placed perpendicular to a time dependent magnetic field $B(t) = (0.4\text{T}) \sin(50 \pi t)$. The field is uniform in space. Then the net charge flowing through the loop during $t = 0 \text{ s}$ and $t = 10 \text{ ms}$ is close to:

- (A) 14 mC (B) 7 mC
 (C) 21 mC (D) 6 mC

22. An infinitely long current carrying wire and a small current carrying loop are in the plane of the paper as shown. the radius of the loop is a and distance of its centre from the wire is d ($d \gg a$). If the loop applies a force F on the wire then:

- (A) $F = 0$ (B) $F \propto \left(\frac{a}{d}\right)$
 (C) $F \propto \left(\frac{a^2}{d^3}\right)$ (D) $F \propto \left(\frac{a}{d}\right)^2$

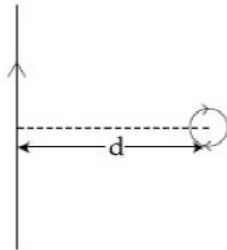

23. A block of mass 10 kg is kept on a rough inclined plane as shown in the figure. A force of 3 N is applied on the block. The coefficient of static friction between the plane and the block is 0.6 . What should be the minimum value of force P , such that the block does not move downward? (take $g = 10 \text{ ms}^{-2}$)

- (A) 32 N (B) 18 N
 (C) 23 N (D) 25 N

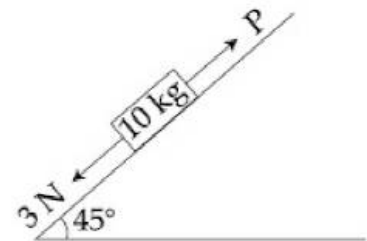

24. A parallel plate capacitor is made of two square plates of side 'a', separated by a distance d ($d \ll a$). The lower triangular portion is filled with a dielectric of dielectric constant K , as shown in the figure. Capacitance of this capacitor is

- (A) $\frac{K\epsilon_0 a^2}{2d(K+1)}$
 (B) $\frac{K\epsilon_0 a^2}{d(K-1)} \ln K$
 (C) $\frac{K\epsilon_0 a^2}{d} \ln K$
 (D) $\frac{1}{2} \frac{K\epsilon_0 a^2}{d}$

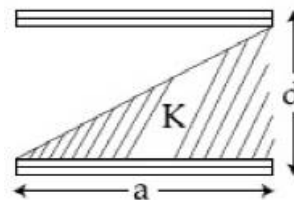

25. A rod of length L at room temperature and uniform area of cross section A , is made of a metal having coefficient of linear expansion $\alpha/^\circ\text{C}$. It is observed that an external compressive force F , is applied on each of its ends, prevents any change in the length of the rod, when its temperature rises by ΔT K. Young's modulus, Y , for this metal is

(A) $\frac{F}{A\alpha\Delta T}$ (B) $\frac{F}{A\alpha(\Delta T - 273)}$
 (C) $\frac{F}{2A\alpha\Delta T}$ (D) $\frac{2F}{A\alpha\Delta T}$

26. A bar magnet is demagnetized by inserting it inside a solenoid of length 0.2 m, 100 turns, and carrying a current of 5.2 A. The coercivity of the bar magnet is

(A) 285 A/m (B) 2600 A/m
 (C) 520 A/m (D) 1200 A/m

27. Three blocks A, B and C are lying on a smooth horizontal surface, as shown in the figure. A and B have equal masses, m while C has mass M . Block A is given an initial speed v towards B due to which it collides with B perfectly inelastically. The combined mass collides with C, also perfectly inelastically. The combined mass

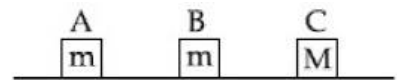

collides with C, also perfectly inelastically if $\frac{5}{6}$ th of the initial kinetic energy is lost in whole process. What is value of M/m ?

(A) 5 (B) 2
 (C) 4 (D) 3

28. When the switch S , in the circuit shown, is closed, then the value of current i will be

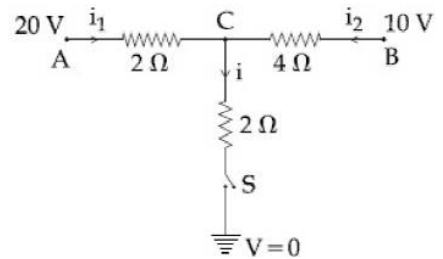

(A) 3 A
 (B) 5 A
 (C) 4 A
 (D) 2 A

29. If the angular momentum of a planet of mass m , moving around the Sun in a circular orbit is L , about the center of the Sun, its areal velocity is:

(A) $\frac{L}{m}$ (B) $\frac{4L}{m}$
 (C) $\frac{L}{2m}$ (D) $\frac{2L}{m}$

30. Two masses m and $\frac{m}{2}$ are connected at the two ends of a massless rigid rod of length ℓ . The rod is suspended by a thin wire of torsional constant k at the centre of mass of the rod-mass system (see figure). Because of torsional constant k , the restoring torque is $\tau = k\theta$ for angular displacement θ . If the rod is rotated by θ_0 and released, the tension in it when it passes through its mean position will be

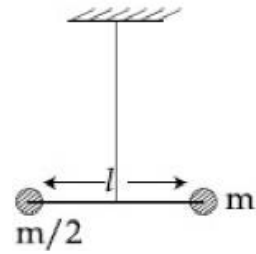

- (A) $\frac{3k\theta_0^2}{\ell}$ (B) $\frac{2k\theta_0^2}{\ell}$
(C) $\frac{k\theta_0^2}{\ell}$ (D) $\frac{k\theta_0^2}{2\ell}$

PART -B (CHEMISTRY)

31. Two complexes $[\text{Cr}(\text{H}_2\text{O})_6]\text{Cl}_3$ (A) and $[\text{Cr}(\text{NH}_3)_6]\text{Cl}_3$ (B) are violet and yellow coloured respectively. The incorrect statement regarding them is
 (A) Δ_0 values of (A) and (B) are calculated from the energies of violet and yellow light, respectively.
 (B) both are paramagnetic with three unpaired electrons
 (C) both absorb energies corresponding to their complementary colours
 (D) Δ_0 value for (A) is less than that of (B)
32. The correct decreasing order for acidic strength is
 (A) $\text{NO}_2\text{CH}_2\text{COOH} > \text{FCH}_2\text{COOH} > \text{CNCH}_2\text{COOH} > \text{ClCH}_2\text{COOH}$
 (B) $\text{FCH}_2\text{COOH} > \text{NCCH}_2\text{COOH} > \text{NO}_2\text{CH}_2\text{COOH} > \text{ClCH}_2\text{COOH}$
 (C) $\text{CNCH}_2\text{COOH} > \text{O}_2\text{NCH}_2\text{COOH} > \text{FCH}_2\text{COOH} > \text{ClCH}_2\text{COOH}$
 (D) $\text{NO}_2\text{CH}_2\text{COOH} > \text{NCCH}_2\text{COOH} > \text{FCH}_2\text{COOH} > \text{ClCH}_2\text{COOH}$
33. The major product of the following reaction is

$$\text{R}-\text{C}\equiv\text{N} \xrightarrow[(2)\text{H}_2\text{O}]{(1)\text{AlH}(\text{i-Bu})_2} ?$$

 (A) RCOOH (B) RCONH_2
 (C) RCHO (D) RCH_2NH_2
34. The highest value of the calculated spin-only magnetic moment (in BM) among all the transition metal complexes is
 (A) 5.92 (B) 6.93
 (C) 3.87 (D) 4.90
35. 0.5 moles of gas A and x moles of gas B exert a pressure of 200 Pa in a container of volume 10 m^3 at 1000 K. Given R is the gas constant in $\text{JK}^{-1}\text{ mol}^{-1}$, x is
 (A) $\frac{2R}{4+R}$ (B) $\frac{2R}{4-R}$
 (C) $\frac{4+R}{2R}$ (D) $\frac{4-R}{2R}$
36. The one that is extensively used as a piezoelectric material is
 (A) tridymite (B) amorphous silica
 (C) quartz (D) mica
37. Correct statements among a to d regarding silicones are
 (i) they are polymers with hydrophobic character
 (ii) they are biocompatible
 (iii) in general, they have high thermal stability and low dielectric strength
 (iv) usually they are resistant to oxidation and used as greases.
 (A) (i), (ii), (iii) and (iv) (B) (i), (ii) and (iii)
 (C) (i) and (ii) only (D) (i), (ii) and (iv)

38. The major product of the following reaction is

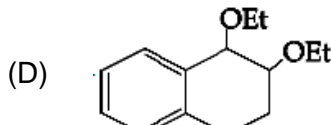
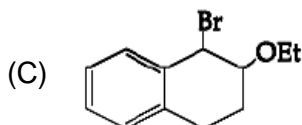
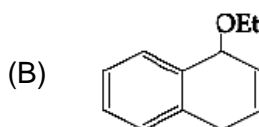
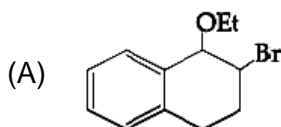
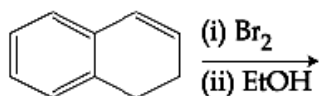

39. In general, the properties that decrease and increase down a group in the periodic table respectively are

- (A) atomic radius and electronegativity (B) electron gain enthalpy and electronegativity
 (C) electronegativity and atomic radius (D) electronegativity and electron gain enthalpy

40. A solution of sodium sulphate contains 92 g of Na^+ ions per kilogram of water. The Molality of Na^+ ions in that solution in mol kg^{-1} is

- (A) 12 (B) 4
 (C) 8 (D) 16

41. The correct match between Item-I and Item-II is:

- | Item – I
(drug) | Item – II
(test) |
|--|--|
| (a) Chloroxylenol | (p) Carbylamine test |
| (b) Norethindrone | (q) Sodium hydrogen carbonate test |
| (c) Sulpha pyridine | (r) Ferric chloride test |
| (d) Penicillin | (s) Bayer's test |
| (A) a \rightarrow r, b \rightarrow p, c \rightarrow s, d \rightarrow q | (B) a \rightarrow q, b \rightarrow s, c \rightarrow p, d \rightarrow r |
| (C) a \rightarrow r, b \rightarrow s, c \rightarrow p, d \rightarrow q | (D) a \rightarrow q, b \rightarrow p, c \rightarrow s, d \rightarrow r |

42. A water sample has ppm level concentration of the following metals:
 Fe = 0.2, Mn = 5.0, Cu = 3.0, Zn = 5.0. The metal that makes the water sample unsuitable for drinking is

- (A) Cu (B) Mn
 (C) Fe (D) Zn

43. The anodic half-cell of lead-acid battery is recharged using electricity of 0.05 Faraday. The amount of PbSO_4 electrolyzed in g during the process is:

- (Molar mass of $\text{PbSO}_4 = 303 \text{ g mol}^{-1}$)
 (A) 22.8 (B) 15.2
 (C) 7.6 (D) 11.4

44. Which one of the following statements regarding Henry's law is not correct?
- (A) Higher the value of K_H at a given pressure, higher is the solubility of the gas in the liquids
- (B) Different gases have different K_H (Henry's law constant) values at the same temperature
- (C) The partial pressure of the gas in vapour phase is proportional to the mole fraction of the gas in the solution
- (D) The value of K_H increases with increase of temperature and K_H is function of the nature of the gas.

45. The following results were obtained during kinetic studies of the reaction
 $2A + B \longrightarrow \text{products}$

Experiment	[A] (in mol L ⁻¹)	[B] (in mol L ⁻¹)	Initial rate of reaction (in mol L ⁻¹ min ⁻¹)
I	0.10	0.20	6.93×10^{-3}
II	0.10	0.25	6.93×10^{-3}
III	0.20	0.30	1.386×10^{-2}

The time (in minutes) required to consume half of A is

- (A) 5
(B) 10
(C) 1
(D) 100
46. Major product of the following reaction is
-
- (A)
- (B)
- (C)
- (D)

47. The alkaline earth metal nitrate that does not crystallise with water molecules is
- (A) $Mg(NO_3)_2$
(B) $Sr(NO_3)_2$
(C) $Ca(NO_3)_2$
(D) $Ba(NO_3)_2$
48. 20 mL of 0.1 M H_2SO_4 is added to 30 mL of 0.2 M NH_4OH solution. The pH of the resultant mixture is [pK_b of $NH_4OH = 4.7$]
- (A) 5.2
(B) 9.0
(C) 5.0
(D) 9.4

49. Adsorption of a gas follows Freundlich adsorption isotherm. In the given plot, x is the mass of gas adsorbed on mass m of the adsorbent at pressure p . $\frac{x}{m}$ is proportional to

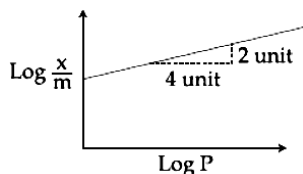

- (A) p^2 (B) $p^{1/4}$
 (C) $p^{1/2}$ (D) p
50. Which amongst the following is the strongest acid?
 (A) CHBr_3 (B) CHI_3
 (C) $\text{CH}(\text{CN})_3$ (D) CHCl_3
51. The ore that contains both iron and copper is
 (A) copper pyrites (B) malachite
 (C) dolomite (D) azurite
52. For emission line of atomic hydrogen from $n_1 = 8$ to $n_f = n$, the plot of wave number ($\bar{\nu}$) against $\left(\frac{1}{n^2}\right)$ will be (The Rydberg constant, R_H is in wave number unit)
 (A) Linear with intercept $-R_H$ (B) Non linear
 (C) Linear with slope R_H (D) Linear with slope $-R_H$
53. The isotopes of hydrogen are
 (A) tritium and protium only (B) protium and deuterium only
 (C) protium, deuterium and tritium (D) deuterium and tritium only
54. According to molecular orbital theory, which of the following is true with respect to Li_2^+ and Li_2^- ?
 (A) Li_2^+ is unstable and Li_2^- is stable (B) Li_2^+ is stable and Li_2^- is unstable
 (C) Both are stable (D) Both are unstable
55. The major product of the following reaction is:

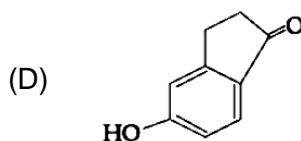
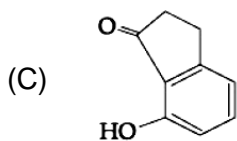
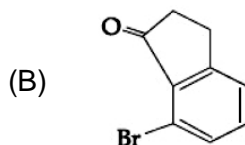
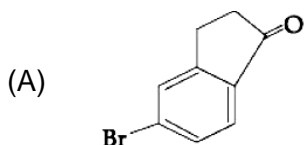
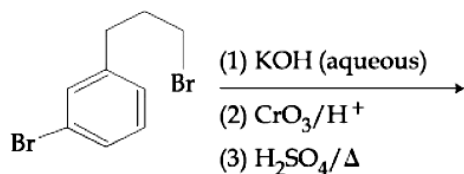

56. Aluminium is usually found in +3 oxidation state. In contrast, thallium exists in +1 and +3 oxidation states. This is due to
 (A) inert pair effect (B) diagonal relationship
 (C) lattice effect (D) lanthanoid contraction
57. The increasing order of pKa of following amino acids in aqueous solution is Gly, Asp, Lys, Arg
 (A) Asp < Gly < Arg < Lys (B) Gly < Asp < Arg < Lys
 (C) Asp < Gly < Lys < Arg (D) Arg < Lys < Gly < Asp
58. Consider the reversible isothermal expansion of an ideal gas in a closed system at two different temperatures T_1 & T_2 ($T_1 < T_2$). The correct graphical depiction of the dependence of work done (w) on the final volume (v).

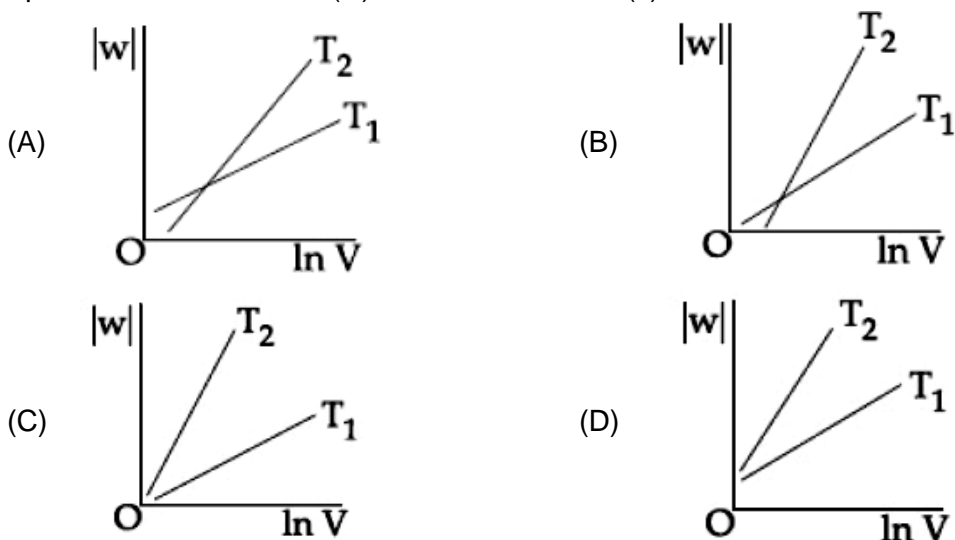

59. Arrange the following amine in the decreasing order of basicity:

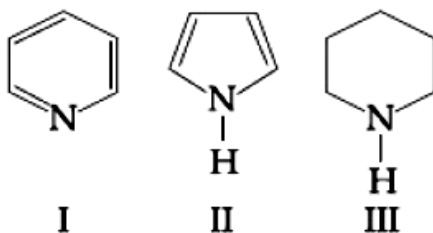

- (A) I > II > III (B) III > I > II
 (C) III > I > I (D) I > III > II

60. The compounds A and B in the following reaction are, respectively

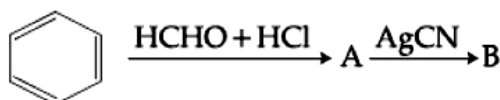

- (A) A = Benzyl alcohol, B = Benzyl cyanide
 (B) A = Benzyl chloride, B = Benzyl cyanide
 (C) A = Benzyl alcohol, B = Benzyl isocyanide
 (D) A = Benzyl chloride, B = Benzyl isocyanide

PART-C (MATHEMATICS)

61. The value of $\int_0^{\pi} |\cos x|^3 dx$ is:
- (A) 0 (B) $\frac{4}{3}$
(C) $\frac{2}{3}$ (D) $-\frac{4}{3}$
62. The maximum volume (in cu.m) of the right circular cone having slant height 3 m is
- (A) 6π (B) $3\sqrt{3}\pi$
(C) $\frac{4}{3}\pi$ (D) $2\sqrt{3}\pi$
63. For $x^2 \neq n\pi + 1, n \in \mathbb{N}$ (the set of natural numbers), the integral
- $$\int x \cdot \sqrt{\frac{2 \sin(x^2 - 1) - \sin 2(x^2 - 1)}{2 \sin(x^2 - 1) + \sin 2(x^2 - 1)}} dx$$
- is
- (A) $\log_e \left| \frac{1}{2} \sec^2(x^2 - 1) \right| + c$ (B) $\frac{1}{2} \log_e \left| \sec(x^2 - 1) \right| + c$
(C) $\frac{1}{2} \log_e \left| \sec^2 \left(\frac{x^2 - 1}{2} \right) \right| + c$ (D) $\log_e \left| \sec \left(\frac{x^2 - 1}{2} \right) \right| + c$
64. If $y = y(x)$ is solution of the differential equation $x \frac{dy}{dx} + 2y = x^2$ satisfying $y(1) = 1$, then $y\left(\frac{1}{2}\right)$ is equal to
- (A) $\frac{7}{64}$ (B) $\frac{1}{4}$
(C) $\frac{49}{16}$ (D) $\frac{13}{16}$
65. Axis of a parabola lies along $x -$ axis. If its vertex and focus are at distance 2 and 4 respectively from the origin, on the positive $x -$ axis then which of the following points does not lie on it?
- (A) $(5, 2\sqrt{6})$ (B) $(8, 6)$
(C) $(6, 4\sqrt{2})$ (D) $(4, -4)$

66. Let $0 < \theta < \frac{\pi}{2}$. If the eccentricity of the hyperbola $\frac{x^2}{\cos^2 \theta} - \frac{y^2}{\sin^2 \theta} = 1$ is greater than 2, then the length of its latus rectum lies in the interval:
- (A) $(3, \infty)$ (B) $\left(\frac{3}{2}, 2\right]$
 (C) $(2, 3]$ (D) $\left(1, \frac{3}{2}\right]$
67. For $x \in \mathbb{R} - [0, 1]$, let $f_1(x) = \frac{1}{x}$, $f_2(x) = 1 - x$ and $f_3(x) = \frac{1}{1-x}$ be three given functions. If a function, $J(x)$ satisfies $(f_2 \circ J \circ f_1)(x) = f_3(x)$ then $J(x)$ is equal to:
- (A) $f_3(x)$ (B) $\frac{1}{x}f_3(x)$
 (C) $f_2(x)$ (D) $f_1(x)$
68. Let $\vec{a} = \hat{i} - \hat{j}$, $\vec{b} = \hat{i} + \hat{j} + \hat{k}$ and \vec{c} be a vector such that $\vec{a} \times \vec{c} + \vec{b} = 0$ and $\vec{a} \cdot \vec{c} = 4$, then $|\vec{c}|^2$ is equal to:
- (A) $\frac{19}{2}$ (B) 9
 (C) 8 (D) $\frac{17}{2}$
69. If a , b and c be three distinct numbers in G.P. and $a + b + c = xb$ then x can not be
- (A) -2 (B) -3
 (C) 4 (D) 2
70. If $\cos^{-1}\left(\frac{2}{3x}\right) + \cos^{-1}\left(\frac{3}{4x}\right) = \frac{\pi}{2}$, $x > \frac{3}{4}$ then x is equal to:
- (A) $\frac{\sqrt{145}}{12}$ (B) $\frac{\sqrt{145}}{10}$
 (C) $\frac{\sqrt{146}}{12}$ (D) $\frac{\sqrt{145}}{11}$
71. Equation of a common tangent to the circle, $x^2 + y^2 - 6x = 0$ and the parabola, $y^2 = 4x$, is:
- (A) $2\sqrt{3}y = 12x + 1$ (B) $\sqrt{3}y = x + 3$
 (C) $2\sqrt{3}y = -x - 12$ (D) $\sqrt{3}y = 3x + 1$
72. The system of linear equation $x + y + z = 2$, $2x + 3y + 2z = 5$, $2x + 3y + (a^2 - 1)z = a + 1$ then
- (A) is inconsistent when $a = 4$ (B) has a unique solution for $|a| = \sqrt{3}$
 (C) has infinitely many solutions for $a = 4$ (D) inconsistent when $|a| = \sqrt{3}$

73. If the fractional part of the number $\frac{2^{403}}{15}$ is $\frac{k}{15}$, then k is equal to:
 (A) 6 (B) 8
 (C) 4 (D) 14
74. The equation of line passing through $(-4, 1, 3)$, parallel to the plane $x + 2y - z - 5 = 0$ and intersecting the line $\frac{x+1}{-3} = \frac{y-3}{2} = \frac{z-2}{-1}$ is:
 (A) $\frac{x+4}{2} = \frac{y+3}{1} = \frac{z+1}{4}$ (B) $\frac{x+4}{1} = \frac{y-3}{1} = \frac{z-1}{3}$
 (C) $\frac{x+4}{3} = \frac{y-3}{-1} = \frac{z-1}{1}$ (D) $\frac{x+4}{-1} = \frac{y-3}{1} = \frac{z-1}{1}$
75. Consider the set of all lines $px + qy + r = 0$ such that $3p + 2q + 4r = 0$. Which one of the following statements is true?
 (A) The lines are concurrent at the point $\left(\frac{3}{4}, \frac{1}{2}\right)$.
 (B) Each line passes through the origin.
 (C) The lines are all parallel
 (D) The lines are not concurrent
76. $\lim_{y \rightarrow 0} \frac{\sqrt{1 + \sqrt{1 + y^4}} - \sqrt{2}}{y^4} =$
 (A) exists and equals $\frac{1}{4\sqrt{2}}$ (B) exists and equals $\frac{1}{2\sqrt{2}(\sqrt{2} + 1)}$
 (C) exists and equals $\frac{1}{2\sqrt{2}}$ (D) does not exist
77. The plane through the intersection of the plane $x + y + z = 1$ and $2x + 3y - z + 4 = 0$ and parallel to y - axis also pass through the point:
 (A) $(-3, 0, -1)$ (B) $(-3, 1, 1)$
 (C) $(3, 3, -1)$ (D) $(3, 2, 1)$
78. If θ denotes the acute angle between the curves, $y = 10 - x^2$ and $y = 2 + x^2$ at a point of their intersection, then $|\tan \theta|$ is equal to
 (A) $\frac{4}{9}$ (B) $\frac{8}{15}$
 (C) $\frac{7}{17}$ (D) $\frac{8}{17}$

79. If $A = \begin{bmatrix} \cos \theta & -\sin \theta \\ \sin \theta & \cos \theta \end{bmatrix}$, then the matrix A^{-50} when $\theta = \frac{\pi}{12}$, is equal to

(A) $\begin{bmatrix} \frac{1}{2} & -\frac{\sqrt{3}}{2} \\ \frac{\sqrt{3}}{2} & \frac{1}{2} \end{bmatrix}$

(B) $\begin{bmatrix} \frac{\sqrt{3}}{2} & -\frac{1}{2} \\ \frac{1}{2} & \frac{\sqrt{3}}{2} \end{bmatrix}$

(C) $\begin{bmatrix} \frac{\sqrt{3}}{2} & \frac{1}{2} \\ -\frac{1}{2} & \frac{\sqrt{3}}{2} \end{bmatrix}$

(D) $\begin{bmatrix} \frac{1}{2} & \frac{\sqrt{3}}{2} \\ -\frac{\sqrt{3}}{2} & \frac{1}{2} \end{bmatrix}$

80. If the Boolean expression $(p \oplus q) \wedge (\sim p \oplus q)$ is equivalent to $p \wedge q$, where $\oplus, \ominus \in \{\wedge, \vee\}$, then the ordered pair (\oplus, \ominus) is :

(A) (\vee, \wedge)

(B) (\vee, \vee)

(C) (\wedge, \vee)

(D) (\wedge, \wedge)

81. 5 students of a class have an average height 150 cm and variance 18 cm². A new student, whose height is 156 cm, joined them. The variance (in cm²) of the height of these six students is:

(A) 16

(B) 22

(C) 20

(D) 18

82. For any $\theta \in \left(\frac{\pi}{4}, \frac{\pi}{2}\right)$, the expression $3(\sin \theta - \cos \theta)^4 + 6(\sin \theta + \cos \theta)^2 + 4\sin^6 \theta$ equals:

(A) $13 - 4\cos^2 \theta + 6\sin^2 \theta \cos^2 \theta$

(B) $13 - 4\cos^6 \theta$

(C) $13 - 4\cos^2 \theta + 6\cos^4 \theta$

(D) $13 - 4\cos^4 \theta + 2\sin^2 \theta \cos^2 \theta$

83. The area (in sq. units) bounded by the parabola $y = x^2 - 1$, the tangent at the point (2, 3) to it and the y-axis is:

(A) $\frac{8}{3}$

(B) $\frac{32}{3}$

(C) $\frac{53}{3}$

(D) $\frac{14}{3}$

84. Let a_1, a_2, \dots, a_{30} be an A.P., $S = \sum_{i=1}^{30} a_i$ and $T = \sum_{i=1}^{15} a_{2i-1}$. If $a_5 = 27a$ and $S - 2T = 75$,

then a_{10} is equal to

(A) 52

(B) 57

(C) 47

(D) 42

HINTS AND SOLUTIONS

PART A – PHYSICS

1. If $u = -10$ cm
 $v = +10$ cm
 $\Rightarrow f = 5$ cm

$$\text{Glass plate shift} = t \left(1 - \frac{1}{\mu} \right) = 1.5 \left(1 - \frac{2}{3} \right) = 0.5 \text{ cm}$$

So, new $u = 10 - 0.5 = 9.5$ cm

$$\frac{1}{v} - \frac{1}{u} = \frac{1}{f}$$

$$\frac{1}{v} - \frac{1}{-9.5} = \frac{1}{5}$$

After solving we get,

$$v = \frac{47.5}{4.5}. \text{ Hence, shift } \frac{47.5}{4.5} - 10 = \left(\frac{2.5}{4.5} \right) = 0.55 \text{ cm}$$

2. Fact based.

3. $i = ne AV_d$
 $1.5 = 9 \times 10^{28} \times 1.6 \times 10^{-19} \times 5 \times V_d$
 $V_d = 0.02$

4. Lets considered mass of each rod is m for stable equilibrium the torque about point O should be zero.
 Torque balance about O

$$mg \frac{a}{2} \sin \theta = mg \left(\frac{a}{2} \cos \theta - a \sin \theta \right)$$

$$\tan \theta = \frac{1}{3}$$

$$\Rightarrow \tan^{-1} \left(\frac{1}{3} \right)$$

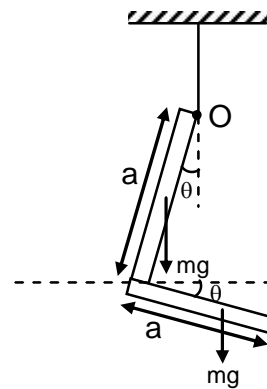

5. $\frac{dx}{dt} = y$; $\frac{dy}{dt} = x$

$$\frac{dx}{dy} = \frac{y}{x}$$

$$\Rightarrow y^2 = x^2 + c$$

6. $\frac{(V_{RMS})_{He}}{(V_{RMS})_{Ar}} = \sqrt{\frac{M_{Ar}}{M_{He}}}$
 $= \sqrt{\frac{40}{4}} = \sqrt{10} = 3.16$

7. Magnetic field at centre of an area subtending angle θ at the centre $\frac{\mu_0 I}{4\pi r} \theta$.

$$B = \left(\frac{\mu_0}{4\pi} \right) \times 10 \left(\frac{1}{3 \times 10^{-2}} - \frac{1}{5 \times 10^{-2}} \right) \frac{\pi}{4}$$

$$= B = \frac{\pi}{30} \times 10^{-4} = \frac{\pi}{3} \times 10^{-5} \approx 10^{-5}$$

8. When $V_{\max} \Rightarrow$ acceleration = 0
 $\Rightarrow x = \frac{F}{K}$

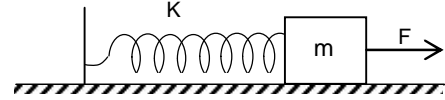

Apply work energy theorem

$$W_{sp} + W_F = \Delta K.E.$$

$$-\frac{1}{2} Kx^2 + F \cdot x = \Delta K.E. \quad ; \quad -\frac{1}{2} K \frac{F^2}{K^2} + \frac{F^2}{K} = \frac{1}{2} m u_{\max}^2$$

$$\frac{F^2}{2K} = \frac{1}{2} m u_{\max}^2 \quad ; \quad \frac{F}{\sqrt{mK}} = V_{\max}$$

9. Electric field

$$E = \frac{kQx}{(x^2 + R^2)^{3/2}}$$

$$\text{For maxima } \frac{dE}{dx} = 0$$

$$\text{After solving we get, } \left(x \pm \frac{R}{\sqrt{2}} \right)$$

10. $\left(\frac{\sqrt{l_1} + \sqrt{l_2}}{\sqrt{l_1} - \sqrt{l_2}} \right) = \frac{16}{1} \quad ; \quad \frac{\sqrt{l_1} + \sqrt{l_2}}{\sqrt{l_1} - \sqrt{l_2}} = \frac{4}{1}$
 $\Rightarrow 3\sqrt{l_1} = 5\sqrt{l_2}$
 $\Rightarrow \frac{l_1}{l_2} = \frac{25}{9}$

11. $\frac{1240}{350} - \phi = (KE)_I = 4x \quad \dots(1)$

$$\frac{1240}{540} - \phi = (KE)_{II} = x \quad \dots(2)$$

$$(1) - (2)$$

$$\frac{1240}{350} - \frac{1240}{540} = 3.542 - 2.296 = 3x$$

$$1.246 = 3x \quad ; \quad x = 0.41$$

$$\phi = 2.296 - 0.41 = 1.886$$

$$12. \quad T_A - T_B = \frac{T_1 - T_2}{\frac{8R}{5}} \times \frac{3R}{5} = \frac{3}{8} \times 120 = 45$$

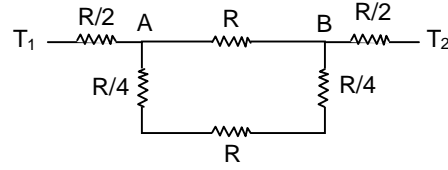

13. As temperature at point A and C is same.
 \therefore Internal energy change will be same.
 $Q - W = Q' - W'$
 $60 - 30 = Q' - 10$
 $Q' = 40 \text{ J}$

$$14. \quad \sin 90^\circ = \mu \sin \theta$$

$$\Rightarrow \quad \sin \theta = \frac{1}{\mu}$$

$$\mu \sin \theta = 1.5 \sin r$$

$$\mu \tan \theta = 1.5$$

$$\Rightarrow \quad \tan \theta = \frac{1.5}{\mu}$$

$$\sin \theta = \frac{3}{\sqrt{9 + 4\mu^2}} = \frac{1}{\mu}$$

$$9\mu^2 = 9 + 4\mu^2$$

$$\Rightarrow \quad \mu = \frac{3}{\sqrt{5}}$$

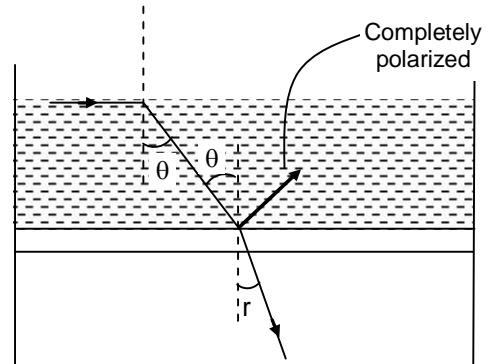

$$15. \quad \text{Use } I = neAv_d \text{ and } \mu = \frac{v_d}{E}$$

$$16. \quad \frac{E}{B} = C$$

$$B = \frac{E}{C} = \frac{6.3 \times 10^{27}}{3 \times 10^8} = 2.1 \times 10^{19}$$

$$17. \quad \frac{k\theta q}{\left(\frac{d}{2}\right)^2} = \frac{k\theta^2}{\left(\frac{3d}{2}\right)^2}$$

$$\Rightarrow \quad 4q = \frac{4Q}{9}$$

$$q = \frac{Q}{9}$$

$$18. \quad R = \frac{\rho \ell}{A}$$

$$R = \frac{\rho \ell^2}{A\ell} = \frac{\rho \ell^2}{V}$$

$$\frac{dR}{R} = \frac{2d\ell}{\ell}$$

Hence, $\frac{dR}{R} = 1\%$.

19. Activity = λ (number of atoms)

$$10 = \lambda_A N_A \quad \dots(1)$$

$$20 = \lambda_B N_B \quad \dots(2)$$

$$N_A = 2N_B \quad \dots(3)$$

Solving we get, $\frac{\lambda_A}{\lambda_B} = \frac{1}{4}$

20. $v = \sqrt{T/\mu} = \sqrt{\frac{Mg}{\mu}}$

$$\frac{\sqrt{g^2 + a^2}}{g} = \left(\frac{60.5}{60}\right)^2$$

$$1 + \frac{1}{2} \frac{a^2}{g^2} = 1 + \frac{1}{60} \text{ using by binomial approximation.}$$

$$\Rightarrow a = \frac{g}{\sqrt{30}}$$

21. $B(t) = 0.4 \sin(50\pi \times 10^{-2})$

$$= 0.4 \sin\left(\frac{50\pi}{100}\right) = 0.4$$

$$\Delta q = \frac{-\Delta Q}{R} = \frac{\Delta Q}{R}$$

$$= \frac{0.4 \times 3.5 \times 10^{-3}}{10} = 140 \text{ mC}$$

No option matching.

22. Force on one pole

$$F = \frac{m \mu_0 I}{2\pi \sqrt{d^2 + x^2}} \quad m = \text{pole}$$

strength

$$\text{Total force} = 2F \sin \theta$$

$$= \frac{2 \times \mu_0 I m \times x}{2\pi \sqrt{d^2 + a^2} \sqrt{d^2 + x^2}} = \frac{\mu_0 I m x}{\pi [d^2 + a^2]}$$

$$= m2x = M = I \pi a^2$$

$$\text{Total force} = \frac{\mu_0 I a^2}{2(d^2 + a^2)}$$

$$\approx \frac{\mu_0 I a^2}{2d^2} \quad [\because d \gg a]$$

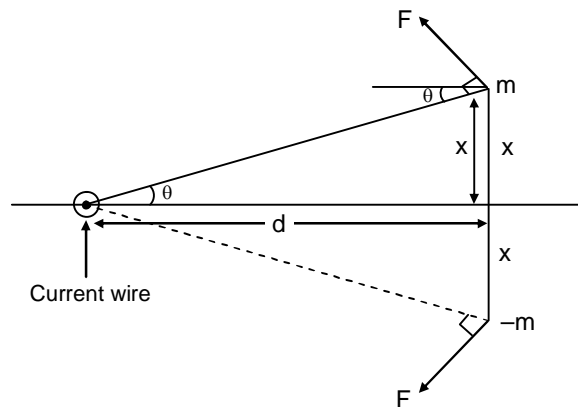

23. For equilibrium of the block net force should be zero. Hence we can write.
 $mg \sin \theta + 3 = P + \text{friction}$
 $mg \sin \theta + 3 = P + \mu mg \cos \theta.$
 After solving, we get, $P = 32 \text{ N}.$

24. Let's consider a strip of thickness dx at a distance of x from the left end as shown in the figure.

$$\frac{y}{x} = \frac{d}{a}$$

$$\Rightarrow y = \left(\frac{d}{a}\right) x$$

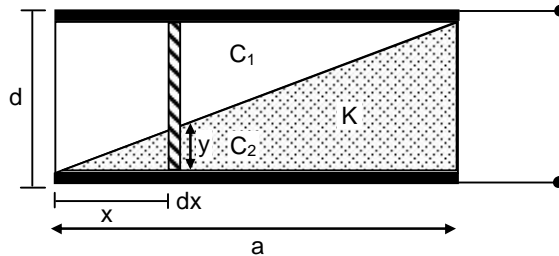

$$C_1 = \frac{\epsilon_0 a dx}{(d-y)} ; C_2 = \frac{k \epsilon_0 a dx}{y}$$

$$C_{\text{eq}} = \frac{C_1 C_2}{C_1 + C_2} = \frac{k \epsilon_0 a dx}{kd + (1-k)y}$$

Now integrating it from 0 to a

$$\int_0^a \frac{k \epsilon_0 a dx}{kd + (1-k)\frac{d}{a}x} = \frac{k \epsilon_0 a^2 \ln k}{d(k-1)}$$

25. $\Delta L = L \propto \Delta T$
 Strain = $\frac{\Delta L}{L} = \alpha \Delta T$; $Y = \frac{F}{A \propto \Delta T}$

26. $B = \mu_0 H$; $\mu_0 n i = \mu_0 H$
 $\frac{100}{0.2} \times 5.2 = H$
 $H = 2600 \text{ A/m}$

27. Apply LMC (Linear Momentum Conservation)
 $mv = (2m + M)v'$

$$v' = \frac{mv}{2m + M}$$

Initial energy

$$\frac{1}{2} mv^2$$

Final energy

$$\frac{1}{2} (2m + M) \left(\frac{mv}{2m + M} \right)^2$$

Initial kinetic energy – Final kinetic energy = $\frac{5}{6}$ of initial kinetic energy.

After solving, we get, $\frac{M}{m} = 4.$

28. $i_3 + i_2 = i_1$
 $\frac{20 - v}{2} + \frac{10 - v}{4} = \frac{v}{2}$
 $v = 10 \text{ V}$
 $\Rightarrow i_1 = \frac{10}{2}$
 $= 5 \text{ amp.}$

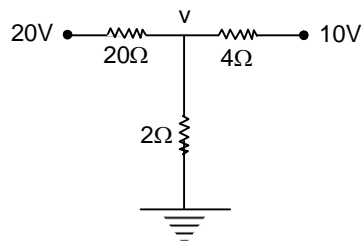

29. Based on Kepler's law.

$$\frac{dA}{dt} = \frac{L}{2m}$$

30. $\Omega = \sqrt{\frac{k}{l}}$; $\omega = \theta_0 \times \Omega$

$$T = m\omega^2 \frac{\ell}{3}$$

$$T = m\omega^2 \frac{\ell}{3} \theta_0 \frac{k}{l} \text{ where } l = m \frac{\ell^2}{3}$$

$$= \frac{\theta_0^2 k}{\ell}$$

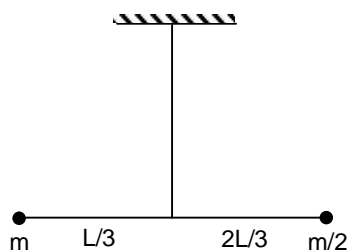

PART B – CHEMISTRY

31. Δ_0 is calculated from the energies of absorbed radiation not from emitted radiation (complementary colour).

32. Acid strength in this case varies directly with the electron withdrawing power of the groups attached to the α -carbon of CH_3COOH . The order of electron withdrawing tendency is $\text{NO}_2 > \text{CN} > \text{F} > \text{Cl}$

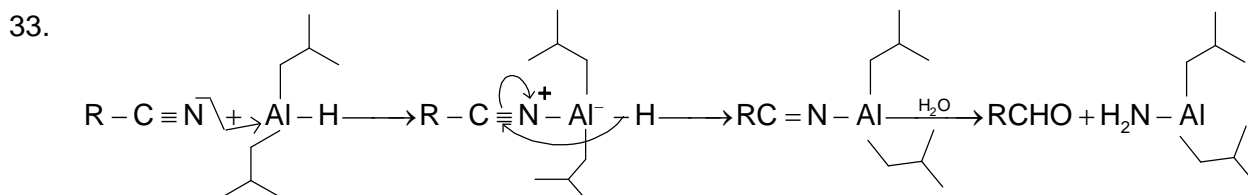

34. Maximum number of unpaired electron of metal or metal ion in complexes = $n = 5$

$$\therefore \mu_s = \sqrt{n(n+2)} = \sqrt{35} = 5.916 \approx 5.92$$

35. $PV = nRT$

$$200 \times 10 = (0.5 + x)R \times 1000$$

$$\text{On solving } x = \frac{4 - R}{2R}$$

36. Materials those produce electric current when they are put under mechanical stress are called piezoelectric materials.

37. Silicones are polymers and hydrophobic due to presence of alkyl groups. They are used as greases as some of them are cyclic.

38.

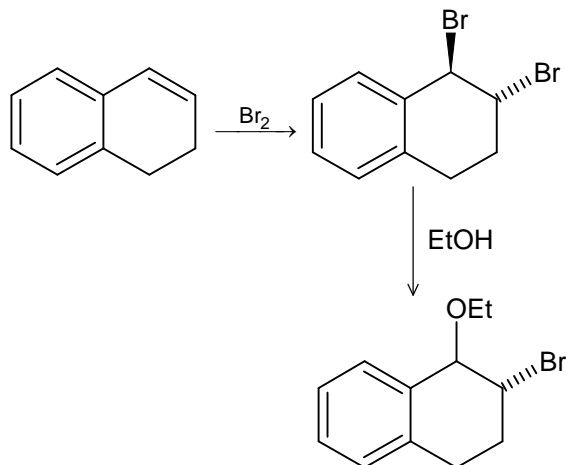

39. On moving down a group, electronegativity decreases and atomic radius increases for representative elements.

40. Molality of $\text{Na}^+ = \left(\frac{w}{M} \times \frac{1000}{W} \right) \times 2$ (Na_2SO_4 contains two Na^+ ions)

$$= \left[\left(\frac{92}{23} \times \frac{1000}{1000} \right) \right] \times 2 = 8$$

41.

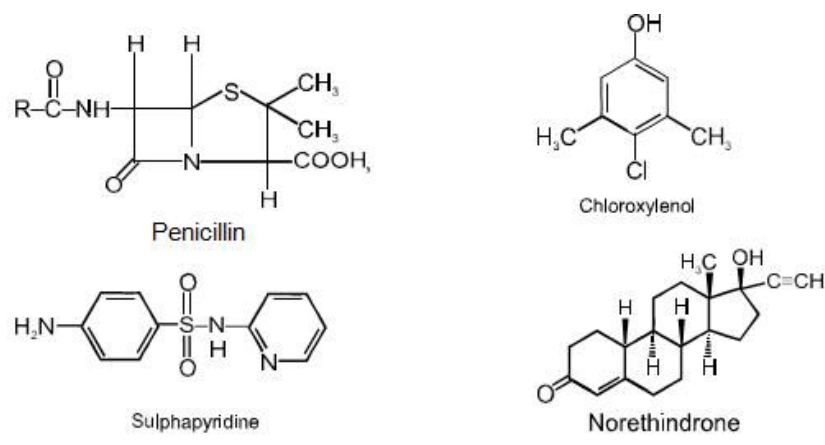

42. The permissible level in ppm unit is

- Fe = 0.2
- Mn = 0.05
- Cu = 3
- Zn = 5
- Mn is higher

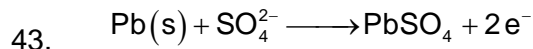

For 2F current passed, PbSO_4 deposited = 303 g/mol

$$\frac{0.05 \times 303}{2} = 7.6 \text{ g}$$

For 0.05 F: PbSO_4 deposited =

44. Gases having higher K_H value are less soluble.

45. $R = k[A]^x [B]^y$

$$6.93 \times 10^{-3} = k (0.1)^x (0.2)^y \quad \text{(i)}$$

$$6.93 \times 10^{-3} = k (0.1)^x (0.25)^y \quad \text{(ii)}$$

$$1.386 \times 10^{-2} = k (0.2)^x (0.3)^y \quad \text{(iii)}$$

$\Rightarrow y = 0$ (from (i) & (ii)), zero order w.r.t. B

$x = 1$ (from (i) & (iii))

\Rightarrow First order wrt A

$$\Rightarrow 6.93 \times 10^{-3} = k (0.1)$$

$$\Rightarrow k = 6.93 \times 10^{-3} \text{ min}^{-1}$$

46.

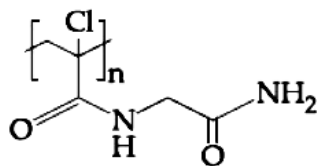
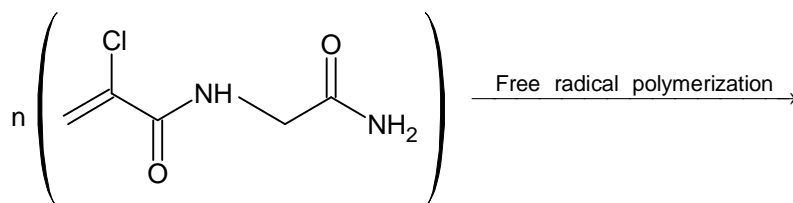
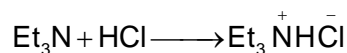
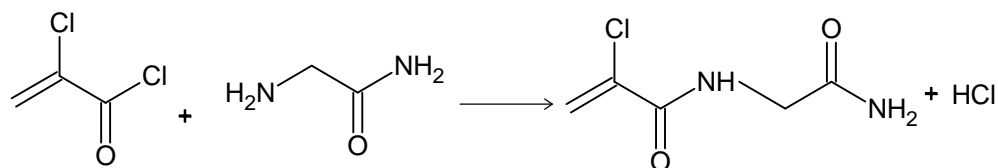

47. Due to larger size of Ba^{2+} ion, $\text{Ba}(\text{NO}_3)_2$ can not hold water molecules during crystallization.

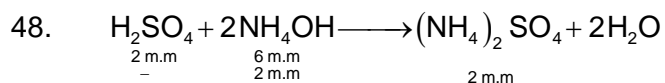

$$\text{pOH} = 4.7 + \log \frac{4}{2} = 5$$

$$\text{pH} = 14 - 5 = 9$$

49. $\frac{x}{m} = KP^{1/n}$

or $\log \frac{x}{m} = \log K + \frac{1}{n} \log P$

Slope = $\frac{1}{n} = \frac{2}{4} = \frac{1}{2}$

$\therefore \frac{x}{m} \propto P^{1/2}$

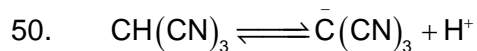

Negative charge of the conjugate base $\bar{\text{C}}(\text{CN})_3$ is extensively delocalized through the $\text{C} \equiv \text{N}$ group.

51. Copper pyrites is CuFeS_2
 Malachite: $\text{CuCO}_3 \cdot \text{Cu}(\text{OH})_2$
 Azurite : $2\text{Cu}(\text{CO})_3 \cdot \text{Cu}(\text{OH})_2$
 Dolomite: $\text{CaCO}_3 \cdot \text{MgCO}_3$

52. For emission line

$n_f < n_i$

$\therefore \bar{\nu} = RZ^2 \left[\frac{1}{n_i^2} - \frac{1}{n_f^2} \right] = R \left[\frac{1}{8^2} - \frac{1}{n^2} \right]$

or, $\bar{\nu} = R_H \left(\frac{1}{64} - \frac{1}{n^2} \right)$

$= \frac{R_H}{64} - \frac{R_H}{n^2}$

$\bar{\nu} = -R_H \left(\frac{1}{n^2} \right) + \frac{R_H}{64}$

$\therefore y = mx + c$

Slope = $-R_H$

53. The isotopes are:

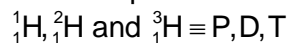

54. Both Li_2^+ and Li_2^- have same bond order. But the number of antibonding electrons is less in Li_2^+ than in Li_2^-

55.

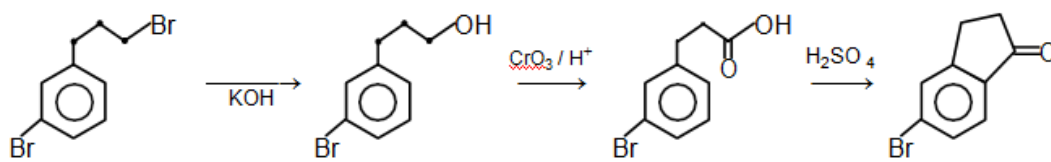

56. The outermost electron configuration of Tl is $6s^26p^1$. The 6s electrons are strongly attracted towards the nucleus due to its more penetrating power and deshielding of d and f-electrons. Hence 6s electrons do not participate in bonding.

57.

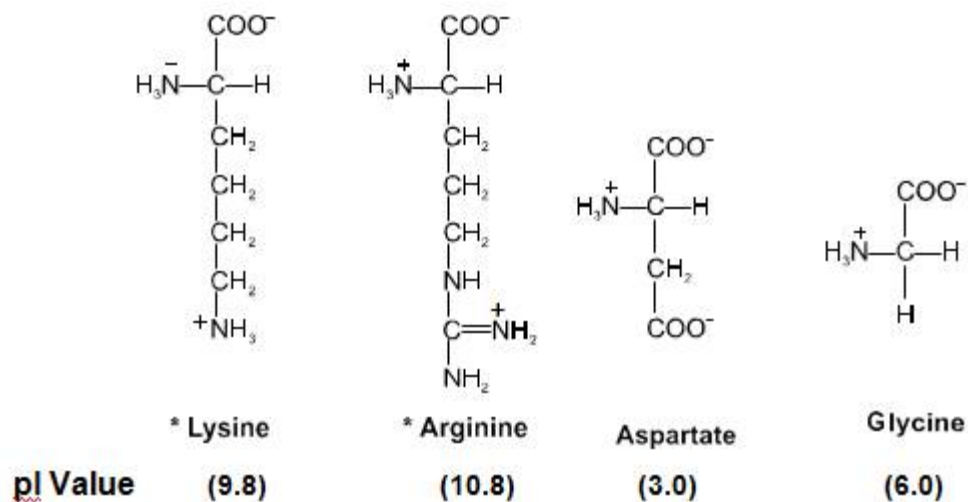

58. Let the gas is expanded from V_1 to V at T_1 and from V_2 to V at T_2
 \therefore At T_1

$$|W_1| = nRT_1 \ln \frac{V}{V_1} = nRT_1 (\ln V - \ln V_1)$$

Similarly at T_2

$$|W_2| = nRT_2 (\ln V - \ln V_2)$$

$$\therefore W_1 = nRT_1 \ln V - nRT_1 \ln V_1$$

$$W_2 = nRT_2 \ln V - nRT_2 \ln V_2$$

Slope of $W_2 >$ Slope of W_1

As $nRT_2 > nRT_1 (T_2 > T_1)$

\therefore The intercept of W_2 is more negative than that of W_1 because $V_2 > V_1$.

59. In(III), nitrogen atom undergoes sp^3 , in(I) sp^2 hybridization. In(II), the lone pair participate in resonance.

60.

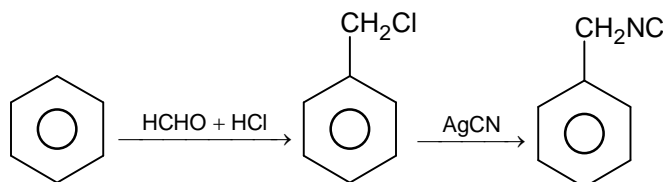

PART C – MATHEMATICS

$$\begin{aligned}
 61. \quad & \int_0^{\frac{\pi}{2}} (|\cos x|^3 + |\cos(\pi - x)|^3) dx \\
 & \Rightarrow 2 \int_0^{\frac{\pi}{2}} |\cos x|^3 dx \\
 & \Rightarrow 2 \int_0^{\frac{\pi}{2}} (\cos x)^3 dx \\
 & \Rightarrow 2 \left(\frac{2}{3} \right) = \frac{4}{3} \text{ (By wallis formula)}
 \end{aligned}$$

$$\begin{aligned}
 62. \quad & \ell = 3 \\
 & r^2 + h^2 = 9 \\
 & \text{Volume of cone is } = \frac{1}{3} \pi r^2 h \\
 & V = \frac{1}{3} \pi h (9 - h^2) \\
 & \frac{dv}{dh} = \frac{1}{3} \pi (9 - 3h^2) = 0 \\
 & 9 - 3h^2 = 0 \\
 & h^2 = 3, h = \sqrt{3} \\
 & V = \frac{1}{3} (\pi) (6) \sqrt{3} = 2\sqrt{3} \pi
 \end{aligned}$$

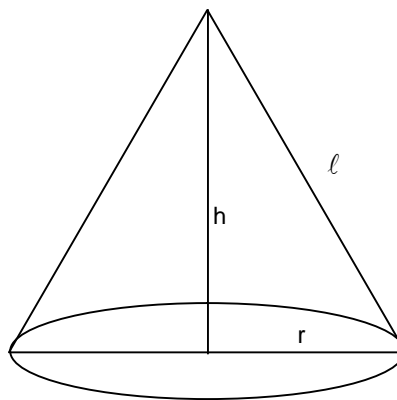

$$\begin{aligned}
 63. \quad & \int x \sqrt{\frac{2 \sin(x^2 - 1)(1 - \cos(x^2 - 1))}{2 \sin(x^2 - 1)(1 + \cos(x^2 - 1))}} dx \\
 & = \int x \frac{\sin\left(\frac{x^2 - 1}{2}\right)}{\cos\left(\frac{x^2 - 1}{2}\right)} dx \\
 & = \int x \tan\left(\frac{x^2 - 1}{2}\right) dx \\
 & \text{Let } \frac{x^2 - 1}{2} = t \Rightarrow 2x dx = 2dt \\
 & = \int \tan(t) dt = \ell n |\sec t| + c \\
 & = \ell n \left| \sec\left(\frac{x^2 - 1}{2}\right) \right| + c
 \end{aligned}$$

64. $x \frac{dy}{dx} + 2y = x^2$

$$\frac{dy}{dx} + \frac{2}{x}y = x$$

This is linear differential equation in $\frac{dy}{dx}$

Integrating factor $= e^{\int \frac{2}{x} dx} = x^2$

Solution of differential equation is $yx^2 = \int x^3 dx$

$$yx^2 = \frac{x^4}{4} + c$$

Curve passes through (1, 1)

then $c = \frac{3}{4}$

$$yx^2 = \frac{x^4 + 3}{4}$$

Put $x = \frac{1}{2}$

$$y\left(\frac{1}{4}\right) = \frac{\left(\frac{1}{2}\right)^4 + 3}{4}$$

$$y = \frac{49}{16}$$

65. Vertex is (2, 0)

$a = 2$

Any general point on given parabola can be taken as $(2 + 2t^2, 4t) \forall t \in \mathbb{R}$.

(8, 6) does not lie on this.

66. $\frac{x^2}{\cos^2 \theta} - \frac{y^2}{\sin^2 \theta} = 1$

$\therefore e > 2$ (given)

$$e^2 > 4 \Rightarrow 1 + \frac{\sin^2 \theta}{\cos^2 \theta} > 4$$

$$\Rightarrow 1 + \tan^2 \theta > 4$$

$$\Rightarrow \tan^2 \theta > 3$$

$$\therefore \theta \in \left(\frac{\pi}{3}, \frac{\pi}{2}\right)$$

Latus rectum $= 2 \frac{\sin^2 \theta}{\cos \theta} = 2 \tan \theta \sin \theta$

\therefore for $\theta \in \left(\frac{\pi}{3}, \frac{\pi}{2}\right)$, $2 \tan \theta \sin \theta$ is increasing function

Hence latus rectum $\in (3, \infty)$

67. $x \in \mathbb{R} - \{0, 1\}$
 $f_1(x) = \frac{1}{x}$, $f_2(x) = 1 - x$, $f_3(x) = \frac{1}{1-x}$
Given $f_2(J(f_1(x))) = f_3(x)$
 $1 - J(f_1(x)) = f_3(x)$
 $J(f_1(x)) = 1 - f_3(x) = 1 - \frac{1}{1-x}$
 $J(f_1(x)) = \frac{x}{x-1}$
 $J\left(\frac{1}{x}\right) = \frac{x}{x-1} = \frac{1}{1-\frac{1}{x}}$
 $J(x) = \frac{1}{1-x} = f_3(x)$

68. $a = \hat{i} - \hat{j}$, $b = \hat{i} + \hat{j} + \hat{k}$, $c = x\hat{i} + y\hat{j} + z\hat{k}$
 $\vec{a} \times \vec{c} + \vec{b} = 0$
 $\Rightarrow \begin{vmatrix} \hat{i} & \hat{j} & \hat{k} \\ 1 & -1 & 0 \\ x & y & z \end{vmatrix} + (\hat{i} + \hat{j} + \hat{k}) = 0$
 $\hat{i}(-z) - \hat{j}(z) + \hat{k}(y+x)$
 $\Rightarrow 1 - z = 0 \Rightarrow z = 1$,
Also $x + y = -1$, and $\vec{a} \cdot \vec{c} = 4 \Rightarrow x - y = 4$
 $\Rightarrow x = \frac{3}{2}$, $y = \frac{5}{2}$
 $\therefore |\vec{c}|^2 = x^2 + y^2 + z^2 = \frac{9}{4} + \frac{25}{4} + 1 = \frac{38}{4} = \frac{19}{2}$

69. $a + ar + ar^2 = xar$
since $a \neq 0$ so $\frac{r^2 + r + 1}{r} = x$; $1 + r + \frac{1}{r} = x$
 $\therefore r + \frac{1}{r} \in (-\infty, -2] \cup [2, \infty) \Rightarrow x \in (-\infty, -1] \cup [3, \infty)$

70. $\cos^{-1}\left(\frac{2}{3x}\right) + \cos^{-1}\left(\frac{3}{4x}\right) = \frac{\pi}{2} \left(x > \frac{3}{4}\right)$
 $\cos^{-1}\left(\frac{2}{3x} \times \frac{3}{4x} - \sqrt{1 - \frac{4}{9x^2}} \sqrt{1 - \frac{9}{16x^2}}\right) = \frac{\pi}{2}$
 $\Rightarrow \frac{1}{2x^2} = \frac{\sqrt{9x^2 - 4} \sqrt{16x^2 - 9}}{12x^2}$

$$\Rightarrow 6 = \sqrt{9x^2 - 4}\sqrt{16x^2 - 9}$$

Square both side

$$36 = 144x^4 - 81x^2 - 64x^2 + 36$$

$$\Rightarrow 144x^4 = 145x^2$$

$$\Rightarrow x^4 = \frac{145x^2}{144} \Rightarrow x = \pm \frac{\sqrt{145}}{12}, 0$$

$$\therefore x > \frac{3}{4} \text{ hence } x = \frac{\sqrt{145}}{12}$$

71. $ty = x + t^2$

$$\left| \frac{3+t^2}{\sqrt{1+t^2}} \right| = 3$$

$$\Rightarrow t = \sqrt{3}$$

$$\Rightarrow \sqrt{3}y = x + 3$$

72. By applying Cramer's Rule

$$D = \begin{vmatrix} 1 & 1 & 1 \\ 2 & 3 & 2 \\ 2 & 3 & a^2 - 1 \end{vmatrix}$$

$$= 3(a^2 - 1) - 6 - 2(a^2 - 1) + 4$$

$$= a^2 - 1 - 2 = a^2 - 3$$

If $|a| \neq \pm\sqrt{3} \Rightarrow$ system has unique solution

$$\left. \begin{array}{l} x + y + z = 1 \\ 2x + 3y + 2z = 1 \\ 2x + 3y + 2z = \pm\sqrt{3} + 1 \end{array} \right\}$$

Hence system is inconsistent for $|a| = \sqrt{3}$

73.
$$\frac{2^{403}}{15} = \frac{2^3 \cdot 2^{400}}{15} = \frac{8 \cdot (1+15)^{100}}{15}$$

$$= \frac{8 \left({}^{100}C_0 + {}^{100}C_1(15) + {}^{100}C_2(15)^2 + \dots \right)}{15}$$

$$\frac{8}{15} + 8 \left({}^{100}C_1(15) + {}^{100}C_2(15)^2 + \dots \right)$$

Remainder is 8.

74. Let the line L be $\frac{x+4}{a} = \frac{y-3}{b} = \frac{z-1}{c}$

$$L \parallel x + 2y - z - 5 = 0$$

$$L \text{ intersects } \frac{x+1}{-3} = \frac{y-3}{2} = \frac{z-2}{-1}$$

$$\Rightarrow \begin{vmatrix} 3 & 0 & 1 \\ a & b & c \\ -3 & 2 & -1 \end{vmatrix} = 0$$

$$\Rightarrow 2a + 0b - 6c = 0$$

$$\text{Also } a + 2b - c = 0$$

$$\therefore \frac{a}{3} = \frac{b}{-1} = \frac{c}{1}$$

$$\therefore L \text{ is } \frac{x+4}{3} = \frac{y-3}{-1} = \frac{z-1}{1}$$

75. $px + qy + r = 0$

$$px + qy + \left(\frac{-3p - 2q}{4}\right) = 0$$

$$p\left(x - \frac{3}{4}\right) + q\left(y - \frac{2}{4}\right) = 0$$

$$x = \frac{3}{4} \text{ and } y = \frac{1}{2}.$$

76. $(1+x)^n \cong 1+nx$ (when $x \rightarrow 0$)

$$\text{So, } \sqrt{1+y^4} = 1 + \frac{y^4}{2}$$

$$\lim_{y \rightarrow 0} \frac{\sqrt{2 + \frac{y^4}{2}} - \sqrt{2}}{y^4}$$

$$= \frac{\sqrt{2} \left(1 + \frac{y^4}{8} - 1\right)}{y^4} = \frac{\sqrt{2}}{8} = \frac{1}{4\sqrt{2}}$$

77. Equation of required plane is

$$(x + y + z - 1) + \lambda(2x + 3y - z + 4) = 0$$

$$\Rightarrow (1 + 2\lambda)x + (1 + 3\lambda)y + (1 - \lambda) = 0$$

$$\text{since given plane is parallel to } y - \text{axis} \Rightarrow 3\lambda + 1 = 0 \Rightarrow \lambda = -\frac{1}{3}$$

$$\text{Hence equation of plane is } x + 4z - 7 = 0$$

78. $y = x^2 + 2$ and $y = 10 - x^2$

$$\text{Meet at } (\pm 2, 6)$$

$$\Rightarrow m_1 = 4 \text{ and } m_2 = -4$$

$$|\tan \theta| = \frac{8}{15}$$

$$79. \quad A = \begin{bmatrix} \cos \theta & -\sin \theta \\ \sin \theta & \cos \theta \end{bmatrix}$$

$$A^2 = \begin{bmatrix} \cos \theta & -\sin \theta \\ \sin \theta & \cos \theta \end{bmatrix} \begin{bmatrix} \cos \theta & -\sin \theta \\ \sin \theta & \cos \theta \end{bmatrix}$$

$$A^2 = \begin{bmatrix} \cos 2\theta & -\sin 2\theta \\ \sin 2\theta & \cos 2\theta \end{bmatrix}$$

By using symmetry

$$A^{-50} = \begin{bmatrix} \cos(-50\theta) & -\sin(-50\theta) \\ \sin(-50\theta) & \cos(-50\theta) \end{bmatrix}$$

$$\text{At } \theta = \frac{\pi}{12}$$

$$A^{-50} = \begin{bmatrix} \cos \frac{25\pi}{6} & \sin \frac{25\pi}{6} \\ -\sin \frac{25\pi}{6} & \cos \frac{25\pi}{6} \end{bmatrix} = \begin{bmatrix} \cos \frac{\pi}{6} & \sin \frac{\pi}{6} \\ -\sin \frac{\pi}{6} & \cos \frac{\pi}{6} \end{bmatrix} = \begin{bmatrix} \frac{\sqrt{3}}{2} & \frac{1}{2} \\ -\frac{1}{2} & \frac{\sqrt{3}}{2} \end{bmatrix}$$

80. Check all option repeatedly

$$(i) (A \wedge B) \wedge (\sim A \vee B) \equiv A \wedge (B \wedge (\sim A \vee B))$$

$$\equiv A \wedge (B) \equiv A \wedge B$$

\Rightarrow (i) is correct

$$(ii) (A \wedge B) \wedge (\sim A \wedge B) \equiv (A \wedge \sim A) \wedge B$$

$$\equiv f \wedge B \equiv f$$

$$(iii) (A \vee B) \wedge (\sim A \vee B) \equiv B$$

$$(iv) (A \vee B) (\sim A \vee B)$$

$$\equiv B \vee (A \wedge \sim A) = B \vee f \equiv B$$

\Rightarrow only (1) is correct

81. Let 5 students are x_1, x_2, x_3, x_4, x_5

$$\text{Given } \bar{x} = \frac{\sum x_i}{5} = 150 \quad \Rightarrow \quad \sum_{i=1}^5 x_i = 750 \quad \dots\dots\dots(1)$$

$$\frac{\sum x_i^2}{5} - (\bar{x})^2 = 18 \Rightarrow \frac{\sum x_i^2}{5} - (150)^2 = 18$$

$$\Rightarrow \sum x_i^2 = (22500 + 18) \times 5 \quad \Rightarrow \quad \sum_{i=1}^5 x_i^2 = 112590 \quad \dots\dots\dots(2)$$

Height of new student = 156 (Let x_6)

$$\text{Then } x_1 + x_2 + x_3 + x_4 + x_5 + x_6 = 750 + 156$$

$$\bar{x}_{\text{new}} = \frac{x_1 + x_2 + x_3 + x_4 + x_5 + x_6}{6} = \frac{906}{6} = 151 \quad \dots\dots\dots(3)$$

$$\text{Variance (new)} = \frac{\sum x_i^2}{6} - (\bar{x}_{\text{new}})^2$$

from equation (2) and (3)

$$\text{variance (new)} = \frac{112590 + (156)^2}{6} - (151)^2 = 22821 - 22801 = 20$$

$$\begin{aligned} 82. \quad & 3(1 - \sin 2\theta)^2 + 6(1 + \sin 2\theta) + 4 \sin^6 \theta \\ &= 3(1 - 2 \sin 2\theta + \sin^2 2\theta) + 6 + 6 \sin 2\theta + 4 \sin^6 \theta \\ &= 9 + 3 \sin^2 2\theta + 4 \sin^6 \theta \\ &= 9 + 12 \sin^2 \theta \cos^2 \theta + 4(1 - \cos^2 \theta)^3 \\ &= 9 + 12(1 - \cos^2 \theta) \cos^2 \theta + 4(1 - 3 \cos^2 \theta + 3 \cos^4 \theta - \cos^6 \theta) \\ &= 13 + 12 \cos^2 \theta - 12 \cos^4 \theta - 12 \cos^2 \theta + 12 \cos^4 \theta - 4 \cos^6 \theta \\ &= 13 - 4 \cos^6 \theta \end{aligned}$$

$$\begin{aligned} 83. \quad \text{Area} &= \int_{-5}^3 x dy - \int_{-1}^3 x dy \\ &= \int_{-5}^3 \left(\frac{y+5}{4} \right) dy - \int_{-1}^3 \sqrt{y+1} dy \\ &= \left[\frac{y^2 + 5y}{4} \right]_{-5}^3 - \left[\frac{2}{3} (y+1)^{3/2} \right]_{-1}^3 \\ &= \left| \frac{\left(\frac{9}{2} + 15 \right) - \left(\frac{25}{2} - 25 \right)}{4} \right| = \left| \frac{16}{3} \right| = \frac{8}{3} \end{aligned}$$

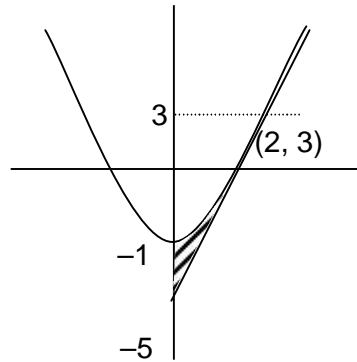

$$84. \quad S = \sum_{i=1}^{30} a_i, \quad T = \sum_{i=1}^{15} a_{2i-1}, \quad a_5 = 27, \quad S - 2T = 75$$

$$\text{Let } a_i = a + (i-1)D$$

$$S = a_1 + a_2 + a_3 + \dots + a_{30}$$

$$T = a_1 + a_3 + a_5 + \dots + a_{29}$$

$$\therefore 2T = 2a_1 + 2a_3 + 2a_5 + \dots + 2a_{29}$$

$$S - 2T = (a_2 - a_1) + (a_4 - a_3) + (a_6 - a_5) + \dots + (a_{30} - a_{29}) = 75$$

$$= 15D$$

$$\text{But } S - 2T = 75 \Rightarrow 15D = 75 \Rightarrow D = 5$$

$$\text{Now } a_5 = 27 \Rightarrow a + 4D = 27$$

$$\therefore a = 27 - 20 \Rightarrow a = 7$$

$$\text{now } a_{10} = a + 9D$$

$$= 7 + 45 = 52$$

85. For $x = 1$
R.H.L = $a + b$
L.H.L = 5
So to be continuous at $x = 1$
 $a + b = 5$ (i)
for $x = 3$
R.H.L. = $b + 15$
L.H.L = $a + 3b$
 $b + 15 = a + 3b$
 $a + 2b = 15$ (ii)
for $x = 5$
R.H.L = 30
L.H.L = $b + 25$
 $b + 25 = 30$
 $b = 5$.
From equation (ii)
 $a = 10$
but $a = 10$ and $b = 5$ does not satisfied equation (i)
So $f(x)$ is discontinuous for $a \in \mathbb{R}$ and $b \in \mathbb{R}$

86.
$$z = \frac{3 + 2i \sin \theta}{1 - 2i \sin \theta} \times \frac{1 + 2i \sin \theta}{1 + 2i \sin \theta}$$

$$z = \frac{(3 - 4 \sin^2 \theta) + 8i \sin \theta}{1 + 4 \sin^2 \theta}$$

For purely imaginary real part should be zero.

i.e. $3 - 4 \sin^2 \theta = 0$.

i.e. $\sin \theta = \pm \frac{\sqrt{3}}{2}$

$\theta = -\frac{\pi}{3}, \frac{\pi}{3}, \frac{2\pi}{3}$, Sum of all values is $-\frac{\pi}{3} + \frac{\pi}{3} + \frac{2\pi}{3} = \frac{2\pi}{3}$

87. Number of ways = Total number of ways without restriction – When two specific boys are in team without any restriction, total number of ways of forming team is ${}^7C_3 \times {}^5C_2 = 350$ If two specific boys B_1, B_2 are in same team then total number of ways of forming team equals to ${}^5C_1 \times {}^5C_2 = 50$ ways total ways = $350 - 50 = 300$ ways

88. $x^2 + 2x + 2 = 0 \Rightarrow (x + 1)^2 = -1$
 $x = -1 \pm i = \sqrt{2} e^{i\left(\pm \frac{3\pi}{4}\right)}$
 $\therefore \alpha^{15}, \beta^{15} = (\sqrt{2})^{15} \times 2 \cos\left(15 \cdot \frac{3\pi}{4}\right)$
 $= 2^8 \sqrt{2} \times \left(-\frac{1}{\sqrt{2}}\right) = -256$

89. Length of direct common tangent for circle C_1 and C_2 is

$$AB = \sqrt{(a+b)^2 - (a-b)^2}$$

For C_2 and C_3

Length of direct common tangent is

$$BC = \sqrt{(a+c)^2 - (a-c)^2}$$

For C_1 and C_3

Length of direct common tangent is

$$AC = \sqrt{(b+c)^2 - (b-c)^2}$$

$$AB + BC = AC$$

$$\sqrt{(a+b)^2 - (a-b)^2} + \sqrt{(a+c)^2 - (a-c)^2}$$

$$= \sqrt{(b+c)^2 - (b-c)^2}$$

$$\sqrt{ab} + \sqrt{ac} = \sqrt{bc}$$

$$\frac{1}{\sqrt{c}} + \frac{1}{\sqrt{b}} = \frac{1}{\sqrt{a}}$$

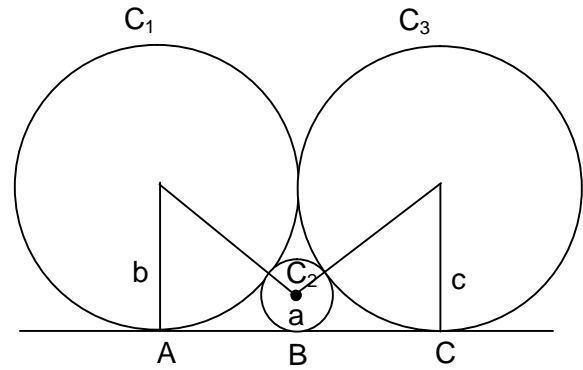

90. $P(x=1) = \frac{4}{52} \times \frac{48}{52} \times 2 = \frac{24}{169}$
- $P(x=2) = \frac{4}{52} \times \frac{4}{52} = \frac{1}{169}$
- $\Rightarrow P(x=1) + P(x=2) = \frac{25}{169}$